

ZXCD50STEVAL

50W CLASS D AUDIO AMPLIFIER EVALUATION BOARD

DESCRIPTION

The ZXCD50STEVAL evaluation board is based on the ZXCD1000 Class D audio amplifier solution from Zetex. This board allows the user to evaluate the high fidelity audio performance offered by the Zetex solution, with an output power up to 50W music power into 4Ω.

INTRODUCTION

The ZXCD50STEVAL is a 50W music power (4Ω load) high performance class D amplifier. The circuitry contains MOSFET devices and should therefore be handled appropriately.

The board requires a single rail power supply of 13 volts minimum and 25 volts maximum. Voltages in excess of 25 volts may cause permanent damage to the board.

The heart of the solution is the ZXCD1000 class D controller IC and the user should refer to the ZXCD1000 data sheet for further technical information. The circuit features pop suppression and over current protection as well as a mute facility.

FEATURES

- Stereo
- Class D architecture
- Single power supply
- Output power ($V_{supply} = 25V$)
 - 50W music into 4Ω
 - 25W music into 8Ω
- THD + N <0.5% @ 90% power
- >90% efficiency
- Flat frequency response 20Hz – 20 kHz
- Turn on / turn off pop suppression
- Over current protection
- Mute facility
- Noise floor -115dB

Note: The ZXCD50STEVAL is intended as an evaluation platform for Zetex Class D solutions. Zetex accepts no liability for external equipment connected to the ZXCD50STEVAL or any other form of consequential damage or loss.

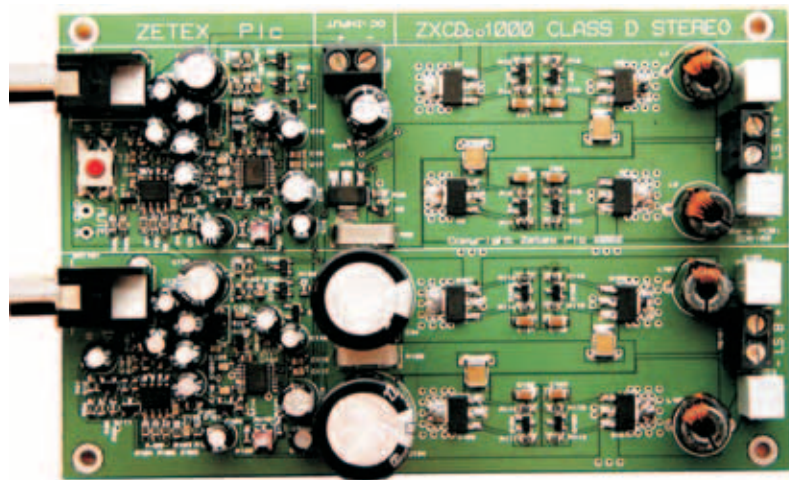

ZXCD50STEVAL

CONNECTION AND OPERATION

The following PCB image shows the connections required for correct operation of the ZXCD50STEVAL board. Simple connector blocks are provided to enable easy connection of the supply voltage, audio inputs and speaker outputs.

Power connection

The ZXCD50STEVAL requires a single positive supply voltage:

25V @ approximately 2.3A for 50W music into 4Ω

Note: 8Ω speakers can be used in this application. In this case a 25V bridge supply will result in an output power of 25W music. If this is required then C2/102 should be removed to maintain a flat frequency response.

The supply should not exceed 25V and must not be less than 13V to ensure correct operation of the amplifier. Ensure the correct polarity of the supply applied.

Audio input

The ZXCD50STEVAL requires a single ended audio input per channel as follows:

The input impedance is 18kΩ.

Input signal amplitude required for full output power is approximately 2.5V peak to peak.

Speaker connection

4Ω speakers may be connected to the board as shown. The correct polarity connection of the speakers is essential to avoid phasing errors.

Note: 8Ω speakers can be used in this application. If this is required then C2/102 should be removed to maintain a flat frequency response.

Over current protection is provided on the board, which prevents damage to the circuit with shorts from the speaker to ground or across the speaker.

EVALUATION BOARD DESCRIPTION AND OPERATION

The top copper, bottom copper and silk screen ID overlay are shown in figure 1,2 and 3.

The ZXCD1000 is available in a 16-pin exposed pad QSOP package. The exposed pad on the underside of the package is soldered down to an area of copper on the PCB, to function as a heatsink. To further assist heat dissipation, the PCB has plated through vias connecting to an area of copper on the underside of the board.

The MOSFETS required on the board are Zetex ZXM64 series HDMOS parts. These SOT223 parts are required to handle the power dissipation in the amplifier with a 50W music load.

The regulator transistors on the board are ZTX692B, E-Line devices. These devices are required to supply the 12V rail to the channels from the board input voltage which is the 25V bridge supply.

The inductors in place on the board have been selected for their excellent linearity and low losses. These components ensure minimal distortion is introduced in the recovered audio signal across the full power band.

The speaker is connected as a Bridge Tied Load (BTL). This means that both sides of the speaker are driven from the Output Bridge and therefore neither side of the speaker connects to ground. This allows maximum power to be delivered to the load, from a given supply voltage.

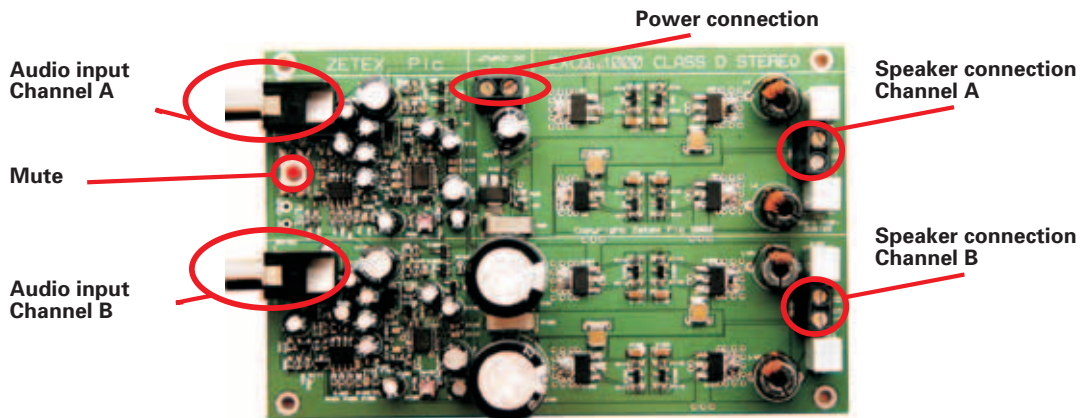

ZXCD50STEVAL

If it is wished to view or measure the signal across the load, a floating monitor must be used - for example a differential probe. Alternatively this may be achieved with a two channel oscilloscope monitoring the speaker A and speaker B outputs, and using the invert and add functions. For diagnostic purposes, the speaker outputs can be monitored single-ended with respect to ground with an oscilloscope (or other instrument) if desired. However any results obtained in this manner, are not valid for assessing performance. The true performance depends upon some differential cancellation across the speaker load.

The board requires an input signal of 2.5V peak to peak nominal to yield the full output power. The input impedance of the board is nominally 18k Ω . This may attenuate the source voltage and may need to be allowed for, depending on the output impedance of the source.

The maximum supply voltage to the ZXCD50STEVAL evaluation board is 25V nominal. A supply voltage of 25V will achieve 50W music into a 4 Ω load.

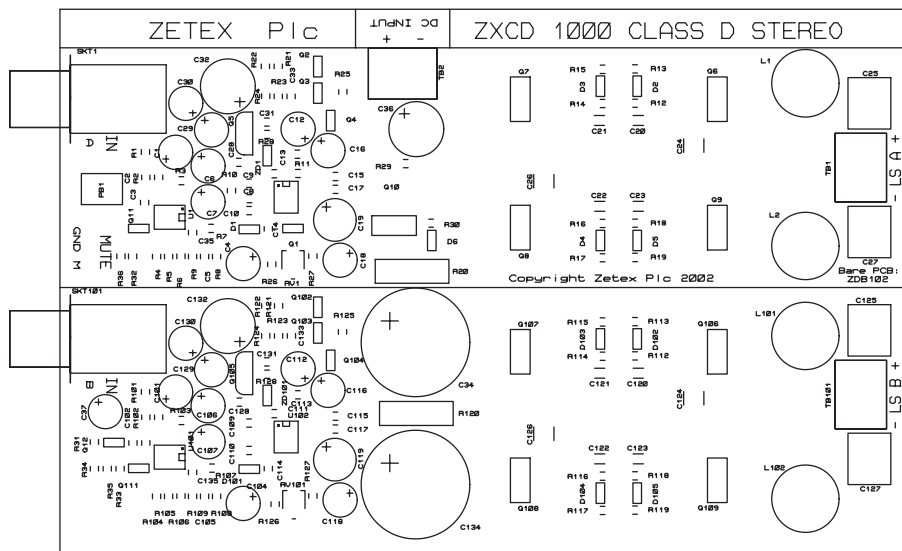

Fig.1. Component Overlay

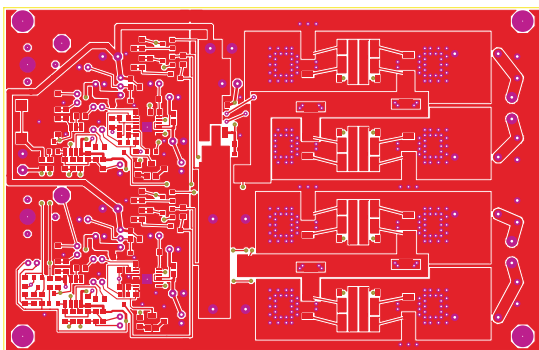

Fig.2. Top Copper

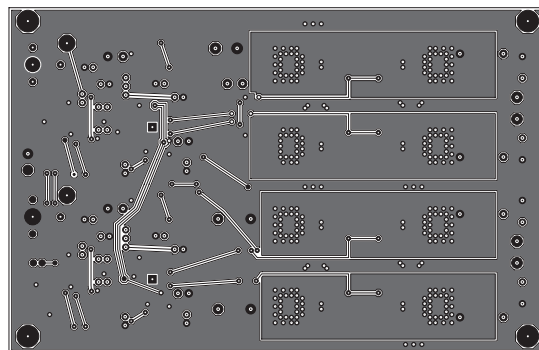

Fig.3. Bottom Copper

ZXCD50STEVAL

ZXCD50STEVAL CIRCUIT DESCRIPTION.

Proprietary circuit design and high quality magnetics are necessary to yield the excellent THD performance of the solution. At the heart of the circuit is the Zetex ZXCD1000 class D audio IC.

The ZXCD50STEVAL circuit diagram is shown in figure 4. The board features two class D channels, one master and one slave. These channels are essentially the same other than the triangle synchronisation facilitated by Q1 on the master channel.

Each audio channel consists of an input phase splitter, the ZXCD1000, an output bridge to drive the load - via L-C filters, and an over-current protection circuit. Each channel also features its own dropper voltage regulator.

The voltage regulator (Q5/105, ZD1/101 etc.) is necessary to drop higher supply voltages (25V on the bridge for 50W) to a level suitable for the ZXCD1000 and input phase splitter (12V on the board).

The input phase splitter per channel, built around the NE5532 dual op amp, is necessary to drive the Audio A and Audio B channels on each ZXCD1000.

Each channel phase splitter features a mute transistor (Q11/111) which is controlled via the circuit built around Q12. This circuit provides a mute function with an active low input. The mute function reduces the effective output signal by 54dB.

The Output Bridges are built around the Zetex XXM64P035G and XXM64N035G PMOS and NMOS SOT223 transistors.

The circuit built around Q10 facilitates a slow start for the bridge supply voltage. This circuit performs anti-pop for the solution.

R20/120 are over current sense resistors. The circuit built around these (Q2/102, Q3/103 etc) enables an over-current protection for the solution. In fault conditions the circuit disables the triangle modulation waveform to the channel and thus disables the output bridge. Protection is given for speaker shorts and speaker to ground shorts.

The ZXCD1000 outputs drive Output Bridge MOSFET's, with the PWM signal, which subsequently drives the load via L-C filters. The purpose of the filters is to low pass filter the high frequency switching PWM signal from the bridge. Thus the lower frequency audio signal is recovered and is available at the speaker outputs.

ZXCD50STEVAL CIRCUIT PERFORMANCE

The graph shown in fig 5 indicates the typical THD performance of the solution. THD is shown from zero up to full power.

Distortion is sub 1% all the way up to full power, typically at 1W 1kHz distortion is 0.1%.

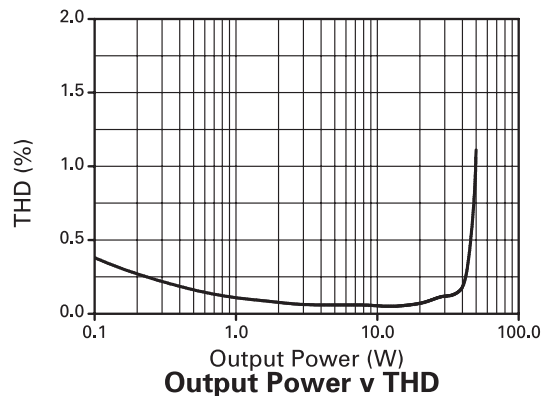

Figure 5.

WARNING - Appropriate safety precautions should be taken by a competent person if the ZXCD1000MOEVAL is to be connected to any potentially hazardous equipment.

ZXCD50STEVAL

Notes.

ISSUE 1 - JULY 2002

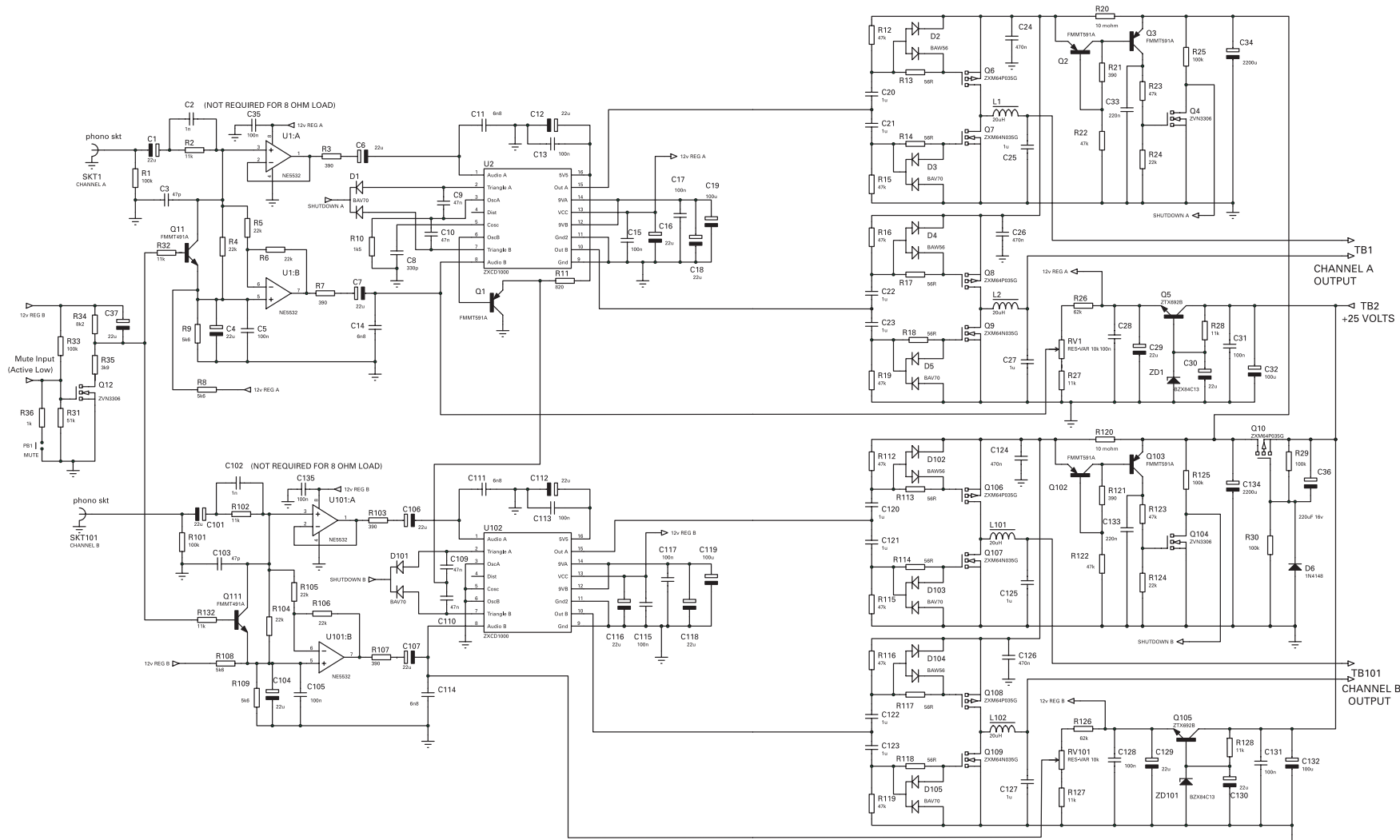

ZXCD50STEVAL

ZETEX CLASS D 50W STEREO DISTRIBUTOR BOARD BOM - REV1

PCB ID	Value	Case	Specific Manufacturer	Part Number	Note
Resistors:-					
R1	100k	1% 0.1W	SMD 0805		Generic
R2	11k	1% 0.1W	SMD 0805		Generic
R3	390	1% 0.1W	SMD 0805		Generic
R4	22k	1% 0.1W	SMD 0805		Generic
R5	22k	1% 0.1W	SMD 0805		Generic
R6	22k	1% 0.1W	SMD 0805		Generic
R7	390	1% 0.1W	SMD 0805		Generic
R8	5k6	1% 0.1W	SMD 0805		Generic
R9	5k6	1% 0.1W	SMD 0805		Generic
R10	1k5	1% 0.1W	SMD 0805		Generic
R11	820	1% 0.1W	SMD 0805		Generic
R12	47k	1% 0.1W	SMD 0805		Generic
R13	56	1% 0.1W	SMD 0805		Generic
R14	56	1% 0.1W	SMD 0805		Generic
R15	47k	1% 0.1W	SMD 0805		Generic
R16	47k	1% 0.1W	SMD 0805		Generic
R17	56	1% 0.1W	SMD 0805		Generic
R18	56	1% 0.1W	SMD 0805		Generic
R19	47k	1% 0.1W	SMD 0805		Generic
R20	0R01	1% 1W	Open Air	Welwyn	OARS series Farnell 327-4561
R21	390	1% 0.1W	SMD 0805		Generic
R22	47k	1% 0.1W	SMD 0805		Generic
R23	47k	1% 0.1W	SMD 0805		Generic
R24	22k	1% 0.1W	SMD 0805		Generic
R25	100k	1% 0.1W	SMD 0805		Generic
R26	62k	1% 0.1W	SMD 0805		Generic
R27	11k	1% 0.1W	SMD 0805		Generic
R28	11k	1% 0.1W	SMD 0805		Generic
R29	100k	1% 0.1W	SMD 0805		Generic
R30	100k	1% 0.1W	SMD 0805		Generic
R31	51k	1% 0.1W	SMD 0805		Generic
R32	11k	1% 0.1W	SMD 0805		Generic
R33	100k	1% 0.1W	SMD 0805		Generic
R34	8k2	1% 0.1W	SMD 0805		Generic
R35	3k9	1% 0.1W	SMD 0805		Generic
R36	1k	1% 0.1W	SMD 0805		Generic
R101	100k	1% 0.1W	SMD 0805		Generic
R102	11k	1% 0.1W	SMD 0805		Generic
R103	390	1% 0.1W	SMD 0805		Generic
R104	22k	1% 0.1W	SMD 0805		Generic
R105	22k	1% 0.1W	SMD 0805		Generic
R106	22k	1% 0.1W	SMD 0805		Generic
R107	390	1% 0.1W	SMD 0805		Generic
R108	5k6	1% 0.1W	SMD 0805		Generic
R109	5k6	1% 0.1W	SMD 0805		Generic
R112	47k	1% 0.1W	SMD 0805		Generic
R113	56	1% 0.1W	SMD 0805		Generic
R114	56	1% 0.1W	SMD 0805		Generic
R115	47k	1% 0.1W	SMD 0805		Generic
R116	47k	1% 0.1W	SMD 0805		Generic
R117	56	1% 0.1W	SMD 0805		Generic
R118	56	1% 0.1W	SMD 0805		Generic
R119	47k	1% 0.1W	SMD 0805		Generic
R120	0R01	1% 1W	Open Air		OARS series Farnell 327-4561
R121	390	1% 0.1W	SMD 0805		Generic
R122	47k	1% 0.1W	SMD 0805		Generic



ZXCD50STEVAL

ZETEX CLASS D 50W STEREO DISTRIBUTOR BOARD BOM - REV1

PCB ID	Value	Case	Specific Manufacturer	Part Number	Note
Resistors :-					
R123	47k	1% 0.1W	SMD 0805		Generic
R124	22k	1% 0.1W	SMD 0805		Generic
R125	100k	1% 0.1W	SMD 0805		Generic
R126	62k	1% 0.1W	SMD 0805		Generic
R127	11k	1% 0.1W	SMD 0805		Generic
R128	11k	1% 0.1W	SMD 0805		Generic
R132	11k	1% 0.1W	SMD 0805		Generic
RV1	10k	0.05W	SMD 3mm preset pot	Meggitt	3203 Series Cermet trimmer Farnell 107-133
RV101	10k	0.05W	SMD 3mm preset pot	Meggitt	3203 Series Cermet trimmer Farnell 107-133
Capacitors :-					
C1	22u	±20% 16V Elect	7mmHx5mmD x2mmP	Multicomp	MCMHR Series Farnell 301-7564 THC 105
C2	1n	50V X7R	SMD 0805		Generic
C3	47p	16V COG	SMD 0805		Generic
C4	22u	±20% 16V Elect	7mmHx5mmD x2mmP	Multicomp	MCMHR Series Farnell 301-7564 THC 105
C5	100n	50V X7R	SMD 0805		Generic
C6	22u	±20% 16V Elect	7mmHx5mmD x2mmP	Multicomp	MCMHR Series Farnell 301-7564 THC 105
C7	22u	±20% 16V Elect	7mmHx5mmD x2mmP	Multicomp	MCMHR Series Farnell 301-7564 THC 105
C8	330p	16V COG/NPO	SMD 0805		Generic
C9	47n	16V X7R	SMD 0805		Generic
C10	47n	16V X7R	SMD 0805		Generic
C11	6n8	16V X7R	SMD 0805		Generic
C12	22u	±20% 16V Elect	7mmHx5mmD x2mmP	Multicomp	MCMHR Series Farnell 301-7564 THC 105
C13	100n	50V X7R	SMD 0805		Generic
C14	6n8	16V X7R	SMD 0805		Generic
C15	100n	50V X7R	SMD 0805		Generic
C16	22u	±20% 16V Elect	7mmHx5mmD x2mmP	Multicomp	MCMHR Series Farnell 301-7564 THC 105
C17	100n	50V X7R	SMD 0805		Generic
C18	22u	±20% 16V Elect	7mmHx5mmD x2mmP	Multicomp	MCMHR Series Farnell 301-7564 THC 105
C19	100u	±20% 16V Elect	11mmHx6.3mmD x2.5mmP	Rubycon	YXF series Farnell 580--417 THC 105
C20	1u	25V X7R	SMD 1206		Generic
C21	1u	25V X7R	SMD 1206		Generic
C22	1u	25V X7R	SMD 1206		Generic
C23	1u	25V X7R	SMD 1206		Generic
C24	470n	50V X7R	SMD 1812		Generic
C25	1u	63V Polyester	5mm pitch		Generic
C26	470n	50V X7R	SMD 1812		Generic
C27	1u	63V Polyester	5mm pitch		Generic
C28	100n	50V X7R	SMD 0805		Generic
C29	22u	±20% 16V Elect	7mmHx5mmD x2mmP	Multicomp	MCMHR Series Farnell 301-7564 THC 105
C30	22u	±20% 16V Elect	7mmHx5mmD x2mmP	Multicomp	MCMHR Series Farnell 301-7564 THC 105
C31	100n	50V X7R	SMD 0805		Generic
C32	100u	±20% 50V Elect	11.5mmHx8mmD x3.5mmP	Rubycon	ZL series Farnell 778-679 THC 105
C33	220n	50V X7R	SMD 0805		Generic

ZXCD50STEVAL

ZETEX CLASS D 50W STEREO DISTRIBUTOR BOARD BOM - REV1

PCB ID	Value	Case	Specific Manufacturer	Part Number	Note
Capacitors :-					
C34	2200u ±20%	31.5mmHx16mmD	Panasonic	FC series	THC 105
	35V Elect	x7.5mmP		Farnell 303-6455	
C35	100n	50V X7R			Generic
C36	220u ±20%	11.5mmHx8mmD	Rubycon	ZL series	THC 105
	25V Elect	x3.5mmP		Farnell 762-090	
C37	22u ±20%	7mmHx5mmD	Multicomp	MCMHR Series	THC 105
	16V Elect	x2mmP		Farnell 301-7564	
C101	22u ±20%	7mmHx5mmD	Multicomp	MCMHR Series	THC 105
	16V Elect	x2mmP		Farnell 301-7564	
C102	1n	50V X7R			Generic
C103	47p	16V COG			Generic
C104	22u ±20%	7mmHx5mmD	Multicomp	MCMHR Series	THC 105
	16V Elect	x2mmP		Farnell 301-7564	
C105	100n	50V X7R			
C106	22u ±20%	7mmHx5mmD	Multicomp	MCMHR Series	THC 105
	16V Elect	x2mmP		Farnell 301-7564	
C107	22u ±20%	7mmHx5mmD	Multicomp	MCMHR Series	THC 105
	16V Elect	x2mmP		Farnell 301-7564	
C109	47n	16V X7R			Generic
C110	47n	16V X7R			Generic
C111	6n8	16V X7R			Generic
C112	22u ±20%	7mmHx5mmD	Multicomp	MCMHR Series	THC 105
	16V Elect	x2mmP		Farnell 301-7564	
C113	100n	50V X7R			Generic
C114	6n8	16V X7R			Generic
C115	100n	50V X7R			Generic
C116	22u ±20%	7mmHx5mmD	Multicomp	MCMHR Series	THC 105
	16V Elect	x2mmP		Farnell 301-7564	
C117	100n	50V X7R			Generic
C118	22u ±20%	7mmHx5mmD	Multicomp	MCMHR Series	THC 105
	16V Elect	x2mmP		Farnell 301-7564	
C119	100u ±20%	11mmHx6.3mmD	Rubycon	YXF series	THC105
	16V Elect	x2.5mmP		Farnell 580-417	
C120	1u	25V X7R			Generic
C121	1u	25V X7R			Generic
C122	1u	25V X7R			Generic
C123	1u	25V X7R			Generic
C124	470n	50V X7R			Generic
C125	1u	63V Polyester			Generic
C126	470n	50V X7R			Generic
C127	1u	63V Polyester			Generic
C128	100n	50V X7R			Generic
C129	22u ±20%	7mmHx5mmD	Multicomp	MCMHR Series	THC 105
	16V Elect	x2mmP		Farnell 301-7564	
C130	22u ±20%	7mmHx5mmD	Multicomp	MCMHR Series	THC 105
	16V Elect	x2mmP		Farnell 301-7564	
C131	100n	50V X7R			
C132	100u ±20%	11.5mmHx8mmD	Rubycon	ZL series	THC 105
	50V Elect	x3.5mmP		Farnell 778-679	
C133	220n	50V X7R			
C134	2200u ±20%	31.5mmHx16mmD	Panasonic	FC series	THC 105
	35V Elect	x7.5mmP		Farnell 303-6455	
C135	100n	50V X7R			Generic

ZXCD50STEVAL

ZETEX CLASS D 50W STEREO DISTRIBUTOR BOARD BOM - REV1

PCB ID	Value	Case	Specific Manufacturer	Part Number	Note
Integrated Circuits					
U1	NE5532AD8	SMD SO8	Phillips		
U2	ZXCD1000EQ16	QSOP16 (Exposed Pad)	Zetex		
U101	NE5532AD8	SMD SO8	Phillips		
U102	ZXCD1000EQ16	QSOP16 (Exposed Pad)	Zetex		
Transistors					
Q1	FMMT591A	SMD SOT23	Zetex		
Q2	FMMT591A	SMD SOT23	Zetex		
Q3	FMMT591A	SMD SOT23	Zetex		
Q4	ZVN3306F	SMD SOT23	Zetex		
Q5	ZTX692B	E Line	Zetex		
Q6	ZXM64P035G	SOT223	Zetex		
Q7	ZXM64N035G	SOT223	Zetex		
Q8	ZXM64P035G	SOT223	Zetex		
Q9	ZXM64N035G	SOT223	Zetex		
Q10	ZXM64P035G	SOT223	Zetex		
Q11	FMMT491A	SMD SOT23	Zetex		
Q12	ZVN3306F	SMD SOT23	Zetex		
Q102	FMMT591A	SMD SOT23	Zetex		
Q103	FMMT591A	SMD SOT23	Zetex		
Q104	ZVN3306F	SMD SOT23	Zetex		
Q105	ZTX692B	E Line	Zetex		
Q106	ZXM64P035G	SOT223	Zetex		
Q107	ZXM64N035G	SOT223	Zetex		
Q108	ZXM64P035G	SOT223	Zetex		
Q109	ZXM64N035G	SOT223	Zetex		
Q111	FMMT491A	SMD SOT23	Zetex		
Diodes					
D1	BAV70	SMD SOT23	Zetex		
D2	BAW56	SMD SOT23	Zetex		
D3	BAV70	SMD SOT23	Zetex		
D4	BAW56	SMD SOT23	Zetex		
D5	BAV70	SMD SOT23	Zetex		
D6	BAS16	SMD SOT23	Zetex		
D101	BAV70	SMD SOT23	Zetex		
D102	BAW56	SMD SOT23	Zetex		
D103	BAV70	SMD SOT23	Zetex		
D104	BAW56	SMD SOT23	Zetex		
D105	BAV70	SMD SOT23	Zetex		
ZD1	BZX84C13	SMD SOT23			13V Zener diode
ZD101	BZX84C13	SMD SOT23			13V Zener diode
Inductors :-					
L1	20uH	PG0036 55-8810-20	Pulse Cambion		
L2	20uH	PG0036 55-8810-20	Pulse Cambion		
L101	20uH	PG0036 55-8810-20	Pulse Cambion		
L102	20uH	PG0036 55-8810-20	Pulse Cambion		

ZXCD50STEVAL

This publication is issued to provide outline information only which (unless agreed by the Company in writing) may not be used, applied or reproduced for any purposes or form part of any order or contract or be regarded as representation relating to the products or services concerned. The company reserves the right to alter without notice the specification, design, price or conditions of supply of any product or service.

Some changes to earlier published data may have been made, data presented in this handbook supersedes all previous specifications. The information contained in this publication has been carefully checked and is considered to be accurate, but no responsibility is assumed for any inaccuracies.

Zetex makes no warranty, representation or guarantee regarding the suitability of the products and circuits in this publication for any given purpose; nor does Zetex assume any liability arising from the use or application of any these products or circuits and specifically disclaims any and all incidental damages.

Zetex products are specifically not authorised for use as critical components in life support devices or systems without the express written approval of the Managing Director of Zetex plc. As used herein -

a. Life support devices or systems are devices or systems which

(1) are intended to implant into the body, or

(2) support or sustain life and whose failure to perform when properly used in accordance with instructions for use provided in the labelling can be reasonable expected to result in significant injury to the user.

b. A critical component is any component on a life support device or system whose failure to perform can be reasonably expected to cause the failure of the life support device or to affect its safety or effectiveness.

E. & O.E.

“all rights reserved”

© Zetex Semiconductors plc 2004

Europe	Americas	Asia Pacific	Corporate Headquarters
Zetex GmbH Streitfeldstraße 19 D-81673 München Germany	Zetex Inc 700 Veterans Memorial Hwy Hauppauge, NY 11788 USA	Zetex (Asia) Ltd 3701-04 Metroplaza Tower 1 Hing Fong Road, Kwai Fong Hong Kong	Zetex Semiconductors plc Lansdowne Road, Chadderton Oldham, OL9 9TY United Kingdom
Telefon: (49) 89 45 49 49 0 Fax: (49) 89 45 49 49 49 europa.sales@zetex.com	Telephone: (1) 631 360 2222 Fax: (1) 631 360 8222 usa.sales@zetex.com	Telephone: (852) 26100 611 Fax: (852) 24250 494 asia.sales@zetex.com	Telephone (44) 161 622 4444 Fax: (44) 161 622 4446 hq@zetex.com

These offices are supported by agents and distributors in major countries world-wide.

This publication is issued to provide outline information only which (unless agreed by the Company in writing) may not be used, applied or reproduced for any purpose or form part of any order or contract or be regarded as a representation relating to the products or services concerned. The Company reserves the right to alter without notice the specification, design, price or conditions of supply of any product or service.

For the latest product information, log on to www.zetex.com



ISSUE 1 - JULY 2002